

Teison



Teison Smart mini

TS-EVC07-003(S)

TS-EVC11-003(S)

TS-EVC22-003(S)



TABLE OF CONTENTS

Start to charge (APP) | 09

Earth rod solution | 12

Fault handling | 14

Teison Profile | 15

Factory history | 16

Product overview | 01

Product features | 02

Parameter | 04

OCPP function list | 05

Size and packaging | 06

Product installation | 07

Product overview

Smart charger, Small size, Stylish design

Easy control via mobile APP, always being the most reliable and safe home charger.



Product features



Solid design wallbox

Meet IP65 & IK10 standard by lab test excellent water protection.



Indicator light

Showing real time charging status



Smart mini

Teison smart components highly integrated in a 228.5x228.5x100 mm Size mini body

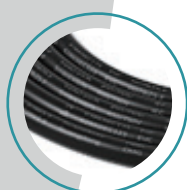

TUV certified

All parts passed CE Certificates, and tested by TUV.



Smart charging

The smartphone App can realize the remote control and organize. Integration with OCPP 1.6 J-SOEN system.

Real Smart

- Control your smart wallbox through Teison App by Bluetooth, WIFI and 4G
- Developed based on OCPP 1.6 J-SON
- Automatic identification
- Max charging Current adjustable
- Remote reach out of every charging process
- Charging records in Cloud
- Scheduled charging to save on your electricity bill
- OTA for new features

Highest safety

- PCV 0 housing with 2.0~3.0 mm thick exudes robustness and protects inside components from external influences.
- The housing is made from materials specially developed for top heat dissipation and with flame retardant coating.
- Completely meets all requirements of the CE applicable standards.
- AC + DC faults detection
- Real-time monitoring for heat and all instabilities during charging process

Parameter

Specification	Model	TS-EVC07-003(S)	TS-EVC11-003(S)	TS-EVC22-003(S)
Electrical Properties	Voltage	230V AC ±10%	380V AC ±10%	380V AC ±10%
	Output Current	32A	16A	32A
	Frequency	50/60Hz	50/60Hz	50/60Hz
	Output Power	7kw	11kw	22kw
	Residual current protection	TYPE A (AC 30MA)		
Design	Charging Outlet	4M charging cable with type1/2 plug or type2 socket		
	Housing Material	PCV0 for outdoor		
	Installation Method	Wall-mount/Floor-stand		
	Communication Protocol	OCPP 1.6 J-SON		
	Safety Standard	EN 61851-1		
	Warranty	2 years		
Environmental Performance	Protection Level	IP65		
	Temperature/Humidity	-30~50°C/5%~95% without condensation		
	Working Altitude	<2000M		
	Application Site	Indoor/Outdoor		
	Working temperature	-30 C ~60 C		
	Storage temperature	-40 C ~70 C		
	Working humidity	5%~95%, No condensation		
	Altitude	≤2000m		
	Salt spray test	Meet IEC 61851-1: 2017		
	Atmospheric pressure	80kPa~101kPa		
	Temperature and humidity cycle	Meet IEC 61851-1: 2017		
Functionality	Network Gateway	Bluetooth and WIFI as default		
	Mobile APP (Ios and Android supported) functions under Bluetooth	Scheduled charging、Start charging、Stop charging、Current adjustment (memorable)、plug and play charging switch on APP、Charging status shown on APP		
	Added APP functions under WIFI / 4G	Charging records shown on mobile APP、view and update the PIN code、firmware updating function(OTA)、multiple wallbox control		
Packing Details	Product Size	228.5*228.5*100mm	228.5*228.5*100mm	228.5*228.5*100mm
	Product Weight	4.4KG	5.2KG	5.4KG
Optional Config	Residual current protection	TYPE B (AC 30MA + DC 6 MA) as optional		
	Network Gateway	4G as optional		
	O-PEN detection	as optional		
	RFID	as optional (with 3 RFID cards)		
	load balance	CT-Clamp / RS485 meter as optional		

OCPP function list

No.	Message	Support or not
1	Authorize	√
2	BootNotification	√
3	ChangeAvailability	√
4	ChangeConfiguration	√
5	ClearCache	√
6	DataTransfer	P
7	GetConfiguration	√
8	Heartbeat	√
9	MeterValues	√
10	RemoteStartTransaction	√
11	RemoteStopTransaction	√
12	Reset	√
13	StartTransaction	√
14	StatusNotification	√
15	StopTransaction	√
16	UnlockConnector	√
17	TriggerMessage	√
18	GetDiagnostics	√
19	DiagnosticsStatusNotification	√
20	FirmwareStatusNotification	√
21	UpdateFirmware	√
22	GetLocalListVersion	√
23	SendLocalList	√
24	ReserveNow	√
25	CancelReservation	√
26	ClearChargingProfile	√
27	GetCompositeSchedule	P
28	SetChargingProfile	√

√ – Supported

P – Need to be combined with the back-end

Product size and packaging

Product size: 228.5*228.5*100mm

Product net weight: 4.4kg

Product gross weight: 5.4kg

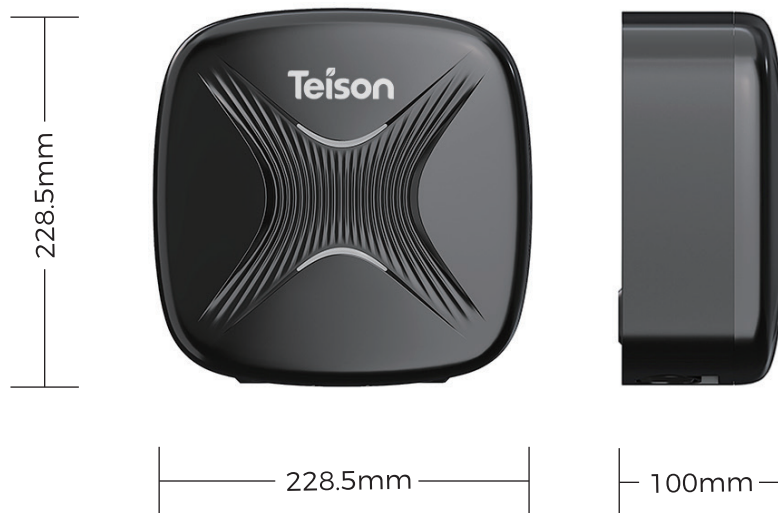

Package:

300*300*200mm

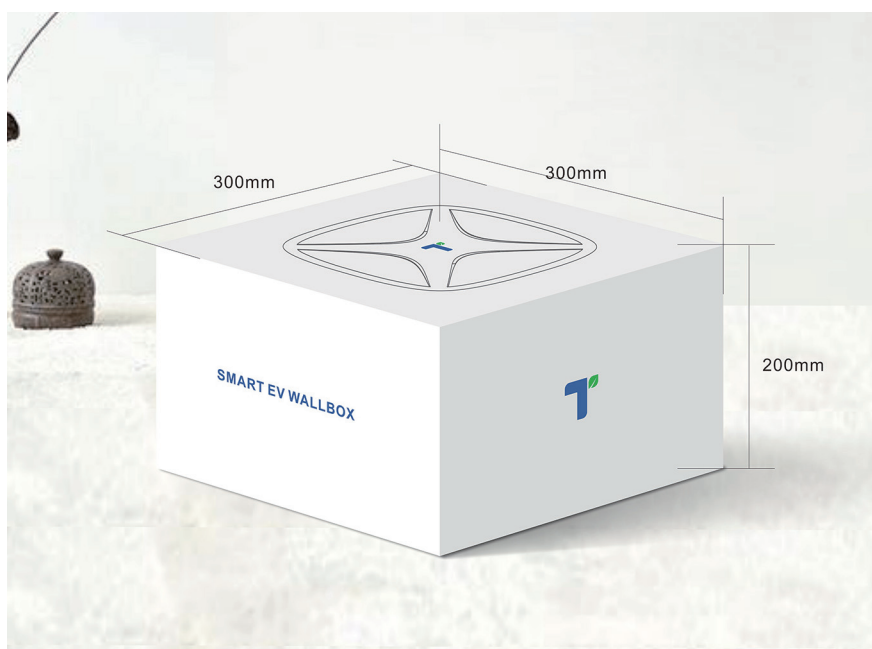

Product installation

Installation method 1

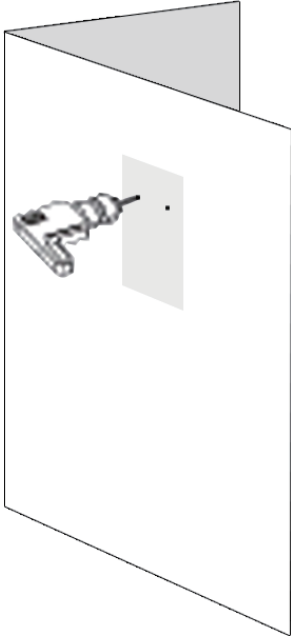

1. Use a drill to make mounting holes in suitable locations on the wall.



2. Tap the expansion bolts into the mounting holes.

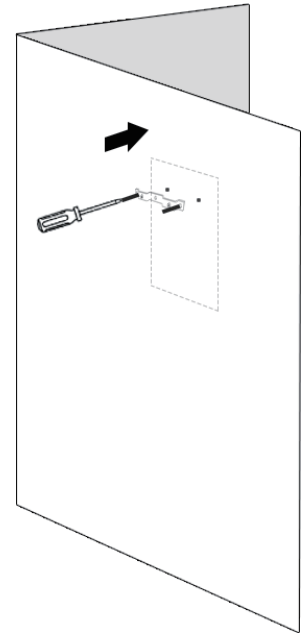

3. Mounting the wallbox back plate on the wall.

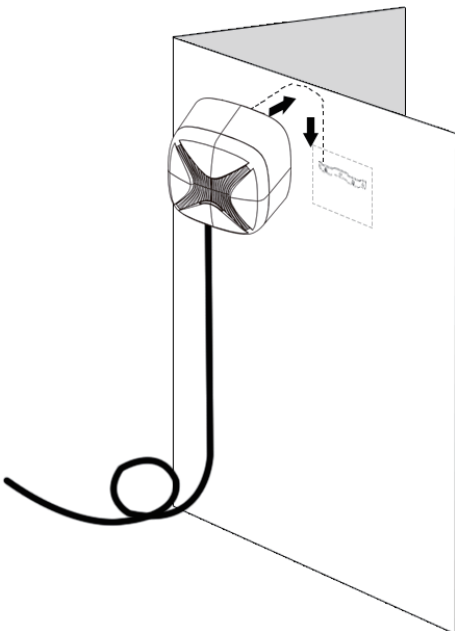

4. Place the wallbox in from the top down and fix it to the back plate

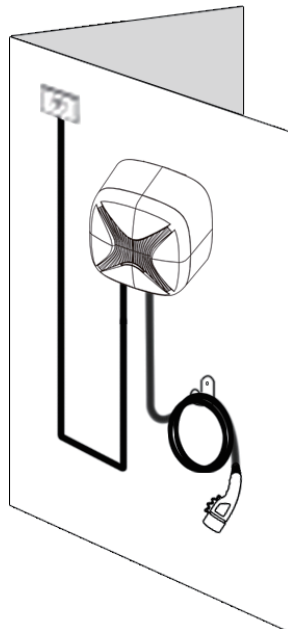

5. Organise and secure the incoming cables of the wallbox.

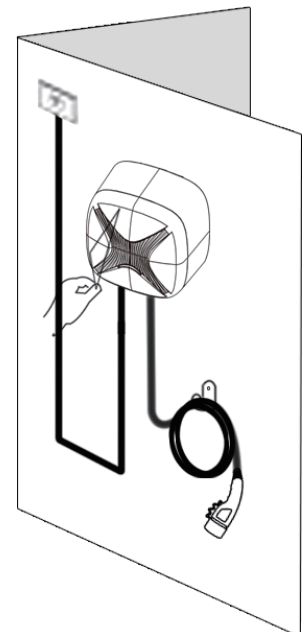

6. Remove the protective film from the front panel to start using the product.

Installation method 2

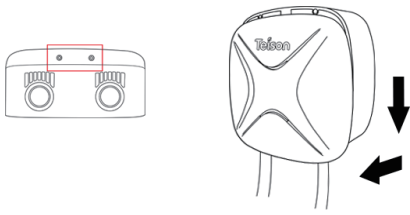

1. Remove the two screws at the bottom of the cover plate, then push down and remove it from the wallbox.

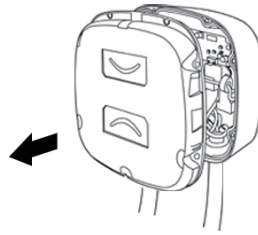

2. Remove the 7 screws around the internal panel and take the panel down.

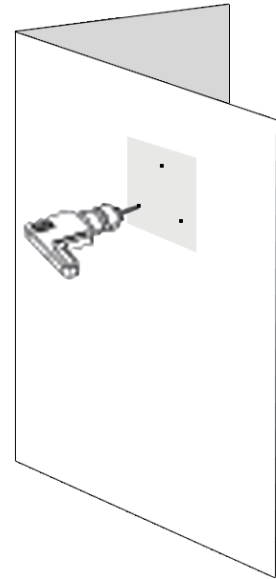

3. Use a drill to make mounting holes in suitable locations on the wall.

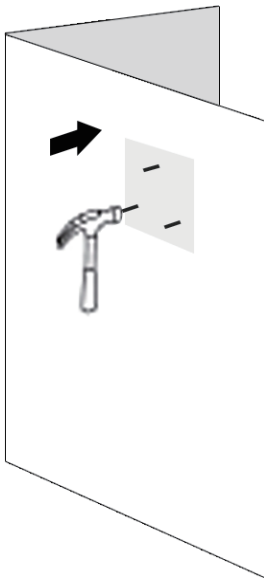

4. Tap the expansion bolts into the mounting holes.

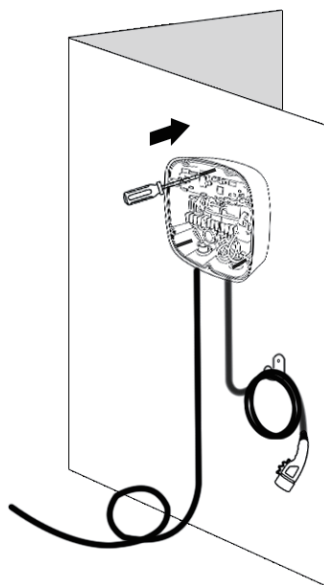

5. Mounting the disassembled back cover on the wall

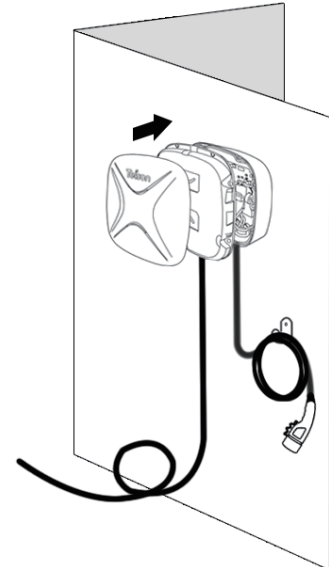

6. Install the removed front panel back in order.

Wiring Diagram

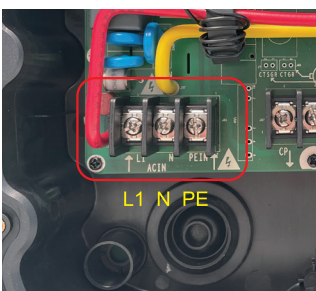

Single-Phase

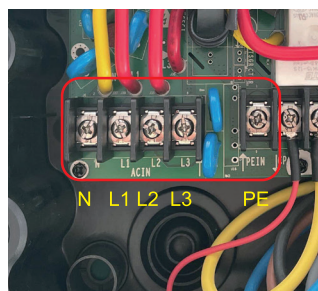

Three-Phase

or

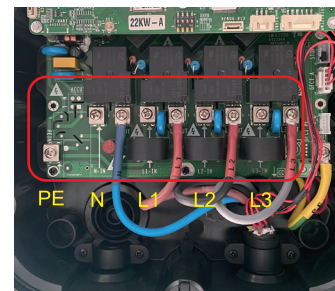

Start to charge (APP)

App need to be given the authority to use the GPS and Bluetooth , at the first to use.

Home(HOME):Support Smart Mini OCPP charger for home user, with Bluetooth and Remote Control
 Commercial:For commercial use in public area, realize charging and operation of the charging stations.

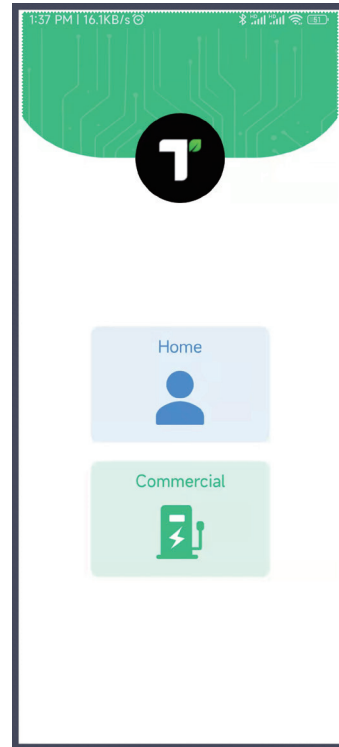
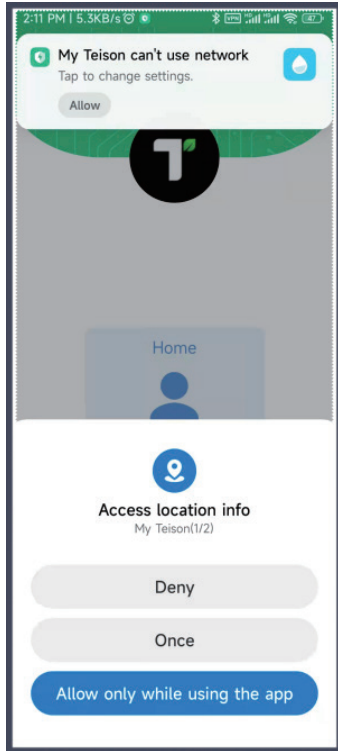

Register your information and login

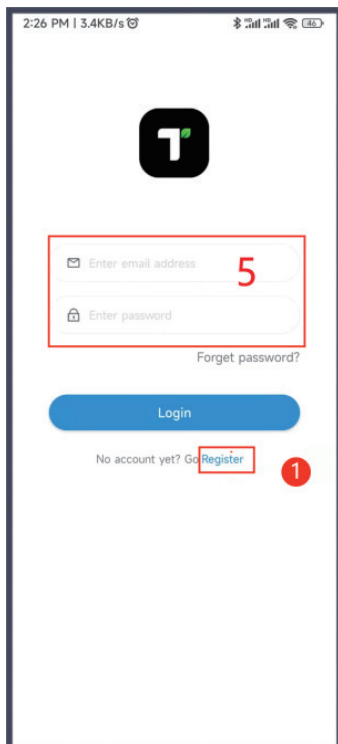

Moile App operation-Connection

1. Local Devices list, press "Use immediately" enter into the user page.
2. Online Devices list, showing all the online chargers bonded by user. Parameters: Device name, Serial No. , Status, type etc. To press "Use immediately" enter into online charger User interface.
3. Press "+Add device" for web configuration.
4. Devices selected area, to find out the correct charging station.

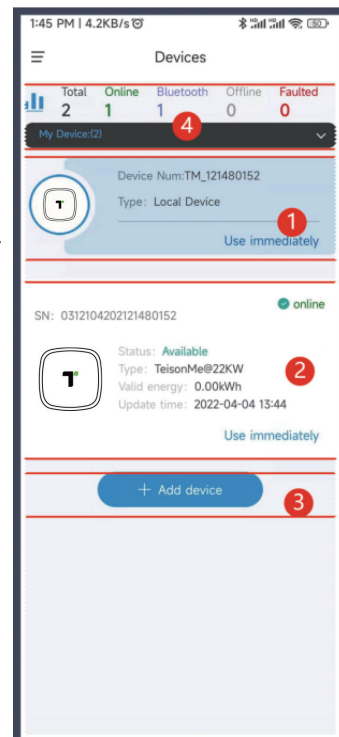

Mobile App operation- Connection:

1. Select : "Use immediately" to use local device.
2. Click the "... "button upper right side.
3. Click "Config Network"
4. By Wi-fi or 4G connection
 - 4.1 If choose Wifi(Only supports 2.4G wifi), input your wifi password .
 - 4.2 If choose 4G, input 4G network APN configuration .
5. Network Configuration will finish in 30seconds.(If you use the ocpp platform by the third-party, it will show success by step 2, have to confirm it by your platform)
6. Config. success. To name your online charger.
7. Back to homepage, the device after success configuring network will show in the list.(if not in the list, pull down to refresh the page).

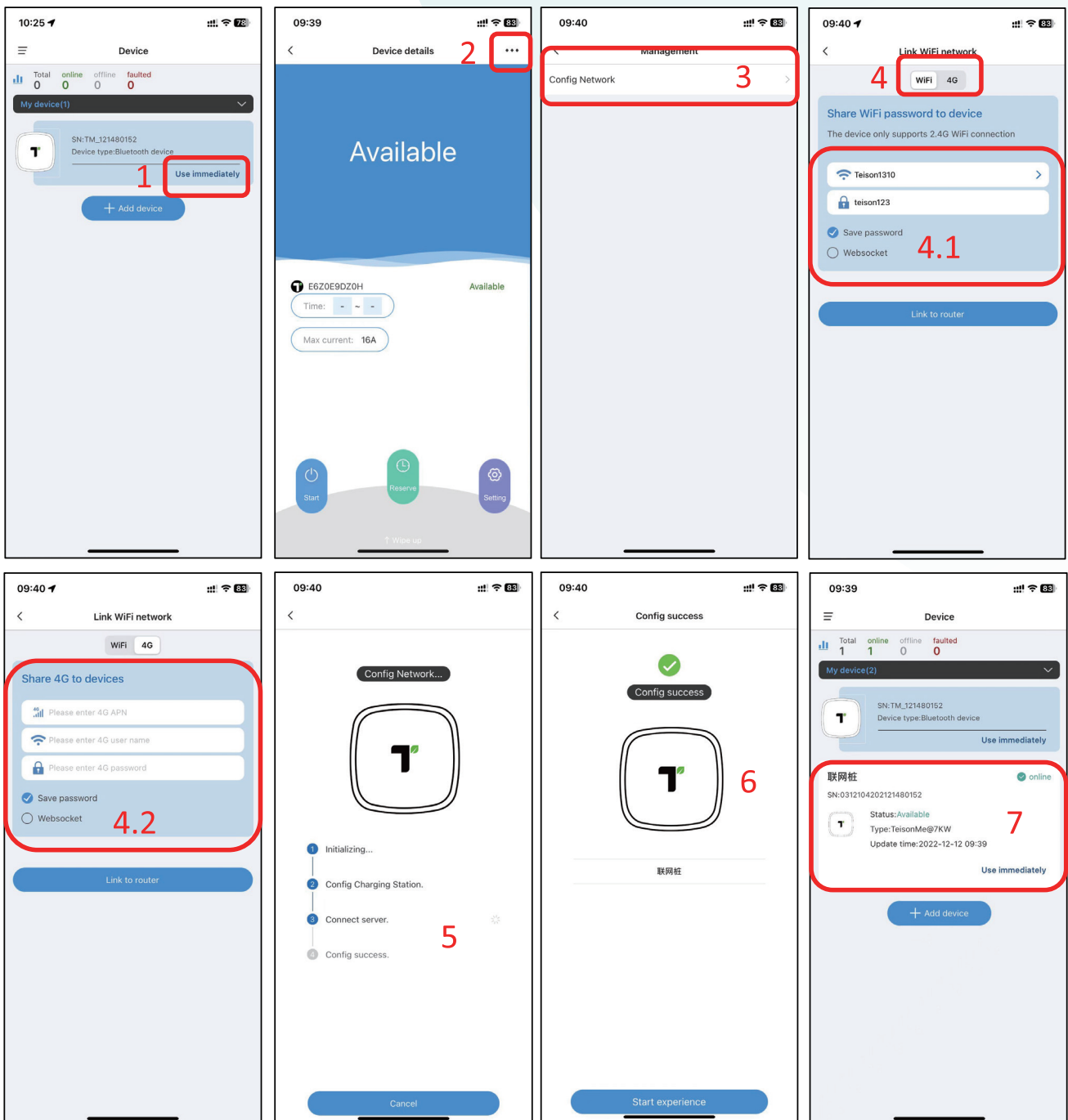

Moile App operation- Pin Code

1. You can check your PIN code by local device management (press “...”on your home page).
2. Copy PIN code or Refresh PIN code
3. Pin Code can be shared to others for the usage of charger

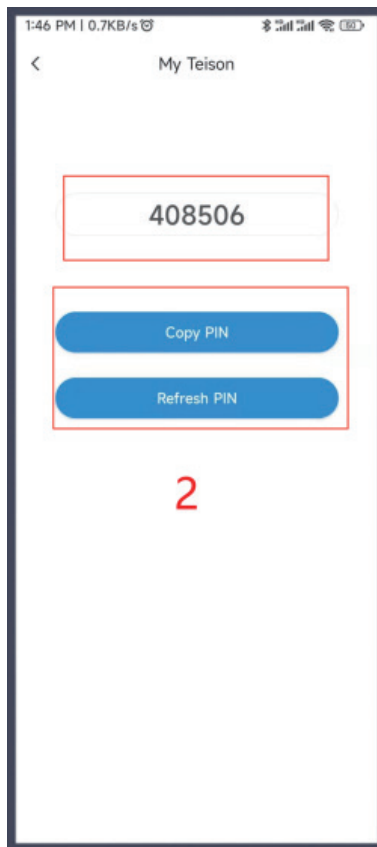

o-PEN: Earth rod solution

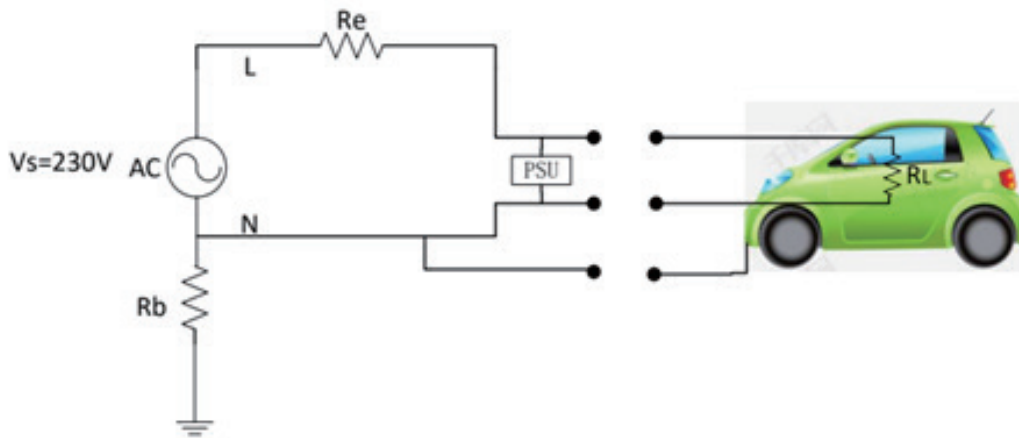

In line with BS 7671: 2018: Amendment 2: 2020 Regulation 722.411.4.1 (iv) Protection against electric shock in a single-phase installation is provided by a device which electrically disconnects the vehicle from the live conductors of the supply and from protective earth in accordance with regulation 543.3.3.101 (ii) within 5 s in the event of the utilisation voltage at the charging point, between the line and neutral conductors, being greater than 253 V rms or less than 207 V rms. The device shall provide isolation and be selected in accordance with Table 537.4. Equivalent means of functionality could be included within the charging equipment. Closing or resetting of the device shall be possible only if the voltage between line and neutral conductors is in the range 207 to 253 V rms.

Preconditions: Some use scenarios cannot provide a good ground (PE) for the charging box, and most cars themselves do not provide a conductive path to the ground, and the car body is generally connected to the PE;

1. Under normal circumstances, the source end of the N line is well grounded, the car is insulated from the ground, and no circuit loop is formed. It is safe at this time.

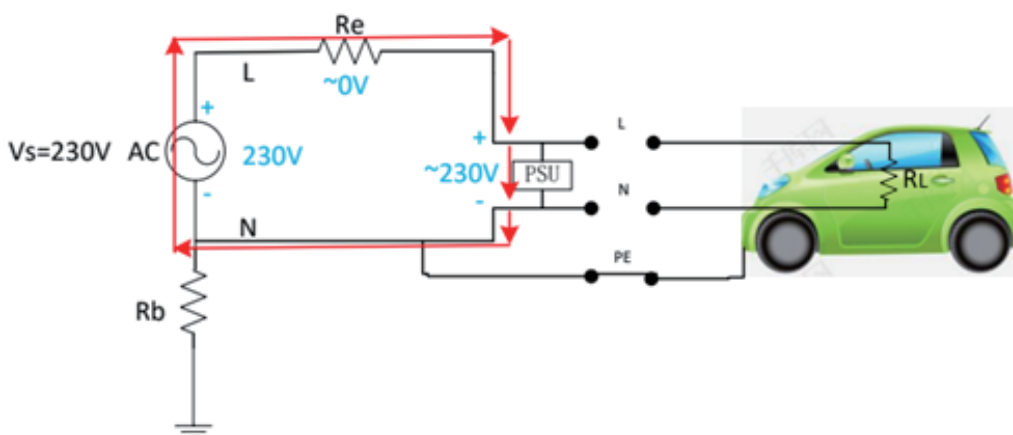

2. When the charging box plug is connected and the human body contacts the car body, it provides a conductive circuit between the car body and the ground. The human body is equivalent to a large resistance and provides a conductive circuit. At this time, there is already a risk. If the incoming line N of the charging pile is well grounded at this time, since R_b is much smaller than the equivalent resistance of the human body, the current flowing through the human body is very small and the human body does not perceive it. People are safe.

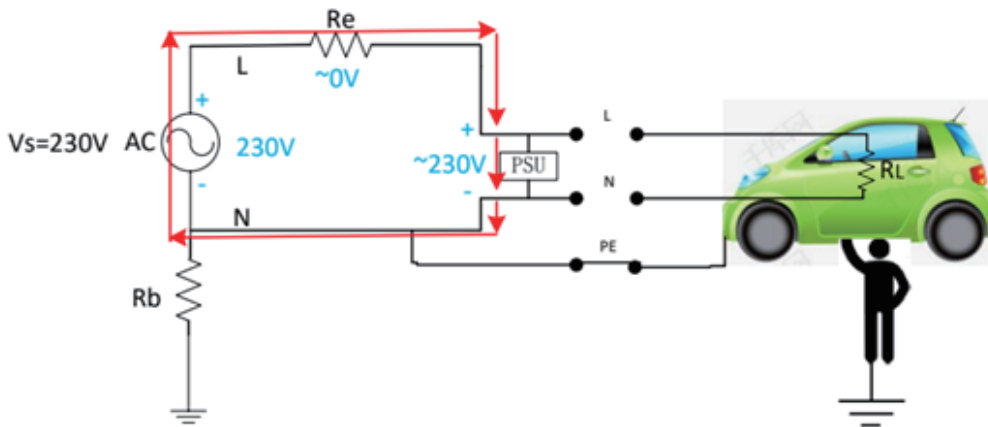

3. When the N line of the charging box is abnormally disconnected or presents a large impedance, the circuit loop will be conducted through the human body to the earth, which will cause the human body to get an electric shock. At this time, the usual L and N leakage protection will be invalid, and new methods are needed. protect.

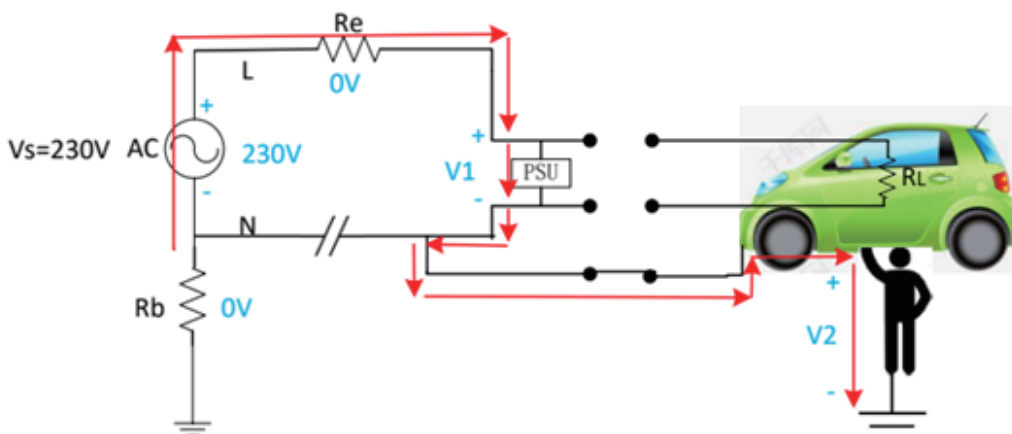

4. Measure 1: $V_1 + V_2 = 230V$, check V_1 , when $V_1 < 170V$, disconnect all paths within 1S to avoid the risk of human electric shock.

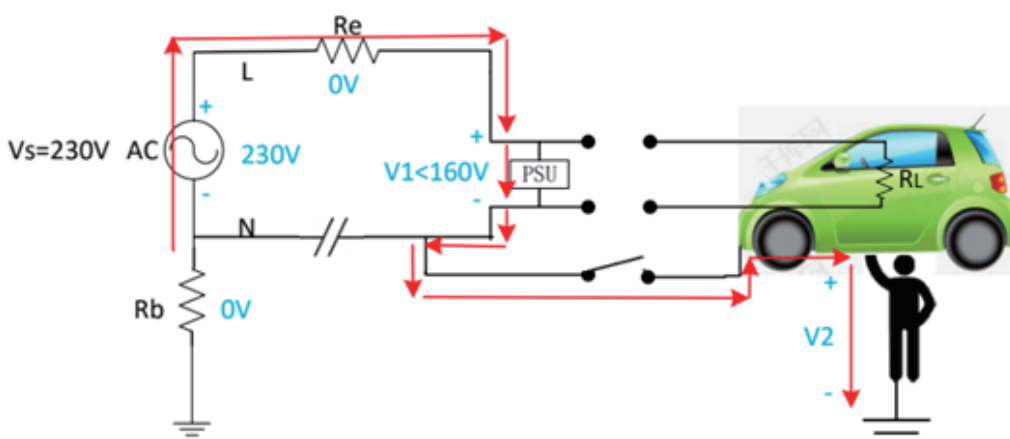

Fault handling

Red light flash times	Condition	LED Status
1	Electric leakage	Below indicator light flash slowly
2	Over-voltage (Input voltage is more than 280v)	
3	Under-voltage (Input voltage is less than 80V)	
4	Over-current (Output current is more than the rated value by 10%)	
5	Over-temperature (Temperature is more than 95 C)	
6	Electric leakage self-testing abnormal	
7	/	
8	CP pilot abnormal	
9	Relay abnormal	
10	Assist processor abnormal	
11	System 12v abnormal	
12	System -12v abnormal	

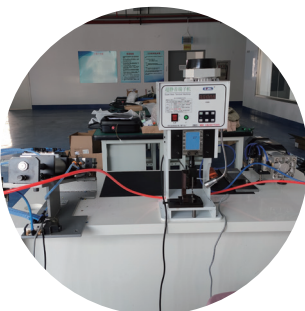

Teison Profile

Teison is a professional EV charging products manufacturer located in Yangzhou city, China. Our products including ev charging station, mode 2 portable ev charger, mode 3 ev charging cable and other accessories, have been applied to more than 32 countries in Europe, North America, Asia and Oceania. Covers an area of 2500 square meters, 50 workers and specialized R&D engineers' team and 4 production lines. Besides ,we have our own QC and test department to control the quality.

Teison passed the ISO9001 quality management system certification, ISO14001 environmental management system certification. Products passed the TUV test ,widely used in different occasions all over the world.

Teison always insists on quality&service first. We sincerely welcome clients around the world to our factory for quality and production line check.

Factory history

2017

Teison brand established, committed to creating the most reliable charging solution for global customers.

2018

1. Fast growing in EU market on Home Wallbox market share.
2. Won good reputation in the European market by Quality and Service.

2019

1. Developed the first LVD+EMC TUV approved IP67 portable ev charger in China for European market.
2. R&D team established for OCPP smart charging solution both on hardware&software.

2020

1. New production base established.
2. Developed OCPP full function Pro wallbox and OCPP platform.
3. Fast growing in EU market on Smart wallbox market share.
4. R&D team established for DC charging station.

2021

1. Developed the first LVD+EMC TUV approved OCPP full function Mini wallbox in China.
2. Developed OCPP DC charging station from 30-360kw.
3. Started to providing customization service for customers.
4. Continue to increase investment in R&D.

2022

1. Production base expended.
2. Fast growing on market share in EU, Asian and South America.
3. Developed dynamic load balance and solar surplus charging solution.
4. Fast growing on DC charging station market share.